

# BLUE<sup>®</sup>

Basic Living Unit for Emergency

## THE NEXT GENERATION OF FAMILY TENTS

ICRC / IFRC / IOM Standard



# BLUE®'S PERFORMANCE AND CHARACTERISTICS

## STABLE IN STRONG WINDS



**BLUE®** resists winds of more than 120 km/hr equal to the wind speeds of a severe tropical storm - with only 6 ground pegs. Its **high-performance aluminium frame** is stronger than a galvanised frame of equal weight.

All of **BLUE®**'s guylines include an **elastic shock absorber** and anti-slip **metal guyrunner** for better tensioning. Both help the tent pegs stay in place in high winds.

## COMFORTABLE IN ALL CLIMATES



**BLUE®**'s 3-layer blackout PE fabric efficiently **reflects light** (visible and infrared). Its **large windows** bring in light and fresh air while its **six roof vents** release hot air and manage condensation.

Its effective **shade cover** provides comfort in blazing hot heat.

The optional **winterization kit** allows to keep warmth inside when it's freezing outside.

## HEALTH AND SAFETY



The tent material is **100% synthetic**. In case of an outbreak of a viral epidemic (cholera, ebola,...), it is fully **washable and disinfectable**.

There is **no surface treatment** applied, limiting the exposure of chemicals to the end-user.

## SLOW FLAME SPREAD



**BLUE®** uses polyethylene (PE) for its outer tent and shade cover.

Compared to classic canvas fabrics, **PE** will **slow the spread of fire** without any FR chemical treatment.

## EASY TO CARRY AND SET UP



The **BLUE®** tent weighs 45 kg, which is **15 kilos lighter** than the current family tent Standard. **BLUE®** comes with an outer tent and shade net. There is an optional inner tent available.

It **sets up easily** with 3 people in only 15 minutes. The **self-standing design** needs less space and can be used everywhere, including warehouses or **urban spaces**.

## LONG LIFESPAN & STORAGE





Being 100% synthetic, **BLUE®** has a **minimum 5 year** shelf life under normal warehousing conditions and minimum 1 year lifespan in all climates. **BLUE®** resists rotting and UV radiation.



## MORE ABOUT BLUE®

BLUE® is designed and produced by Alpinter in collaboration with ICRC/IFRC. It is the newest generation of shelter for refugees, IDPs and other vulnerable families. It is a **100% synthetic, self-standing, geodesic family tent**, meeting IFRC/ICRC/IOM latest standard.

		46,5 Kg
<b>PACKING</b>		0,18 m <sup>3</sup>

SIDE VIEW

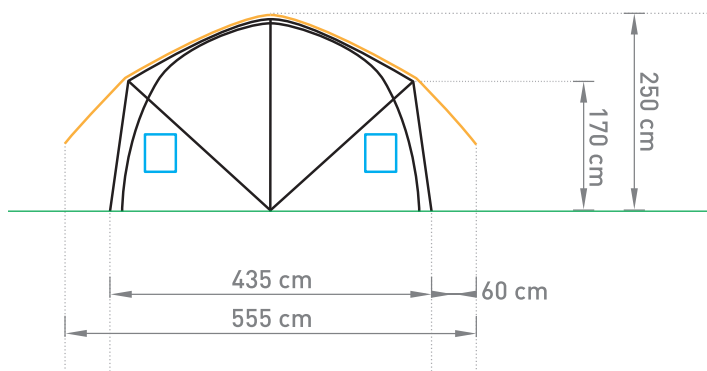

TOP VIEW

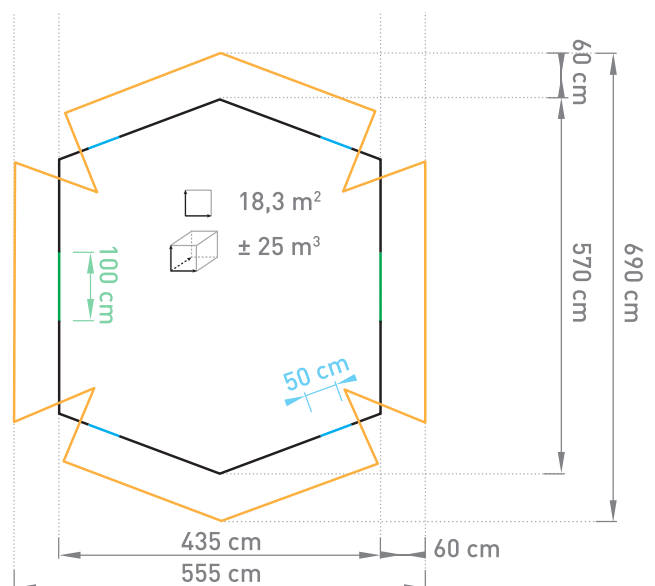

# BLUE®'S OPTIONS

## INNER TENT

By adding a 3<sup>rd</sup> layer, we increase the comfort and insulation of the tent. The inner tent is made out of **lightweight and highly breathable FR polyester**, designed to keep occupants **as comfortable as possible**.

 8,5 Kg  
**PACKING**  0,035 m<sup>3</sup>

SIDE VIEW

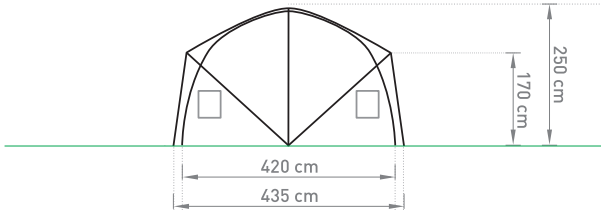

TOP VIEW

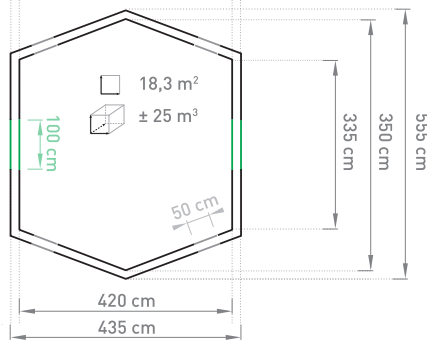

## WINTERIZATION KIT - *Under development*

Made with the same quality PE material as **BLUE®**, the winterization kit is an **insulating layer** on the tent that keeps the warmth inside.

It creates an **additional 8.4 sqm space** for storage in its **2 vestibules**. The kit offers excellent **resistance to snowfall** and makes **BLUE®** the ideal shelter for any climate.

 45 Kg  
**PACKING**  0,18 m<sup>3</sup>

SIDE VIEW

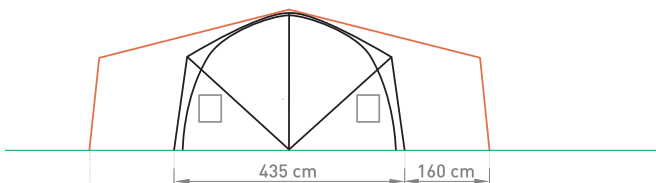

TOP VIEW

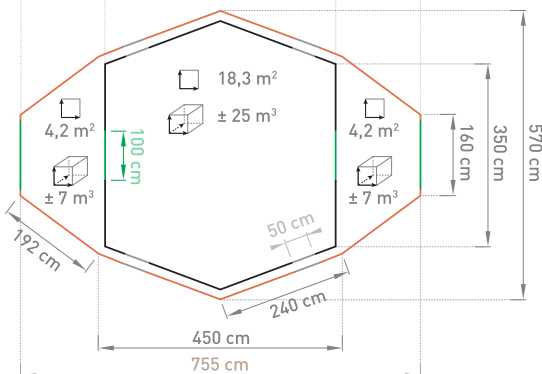

# BLUE® 'S MATERIALS

Alpinter was the first manufacturer to introduce **Blackout woven PE** in a tent's material. The **BLUE®** is a groundbreaking design that offers tangible benefits for the beneficiary.

## SHADE COVER + OUTER TENT

3 LAYER WOVEN POLYETHYLENE (PE)



- Disinfectable
- Lightweight
- UV-resistant
- Recyclable
- Good privacy/opacity
- Reflects and blocks visible infrared light
- Limited flame spread
- Durable
- Not fungi/mould sensitive
- No chemical surface treatment

## FRAME - ALUMINIUM RODS



- High strength to weight ratio
- Premium quality aluminium alloy 6061 T6
- Lightweight
- Durable
- Corrosion free

## OPTIONAL INNER TENT

POLYESTER (PES)



- Permanently flame retardant
- Breathable
- No chemical exposure
- Durable
- Not fungi/mould sensitive
- Disinfectable
- No surface treatment

Established in 1988, Alpinter is headquartered in Belgium with offices worldwide. We develop, produce and supply core relief items. Our tent designs have set the standard for humanitarian purposed tents and are adopted by the world leading NGO's.

Our products are subjected to rigourous field and laboratory testing. We turn questions into answers by working closely with you.

We hold stock in strategic locations worldwide. Thanks to our dedicated logistics service, we're available 24/7. We can respond quickly to any emergency worldwide.

#### HEAD OFFICE

##### ALPINTER BELGIUM

CHARLES DE GAULLESTR. 7  
B-9600 RENAIX - RONSE | BELGIUM | **EUROPE**  
Tel: +32 (0)55 23 17 54

#### REGIONAL OFFICES

##### ALPINTER BULGARIA

35-37 KLOKOTNITZA ST | AP.1  
1233 | SOFIA  
BULGARIA

##### ALPINTER DUBAI

INTERNATIONAL HUMANITARIAN CITY  
BUILDING N° 1 | SECOND FLOOR | OFFICE 207  
DUBAI INDUSTRIAL CITY | PO BOX 506047  
DUBAI | U.A.E. | **MIDDLE EAST**

##### ALPINTER UGANDA

PLOT 224-226, KYEYUNE ROAD | KIGGUNDU ZONE  
KANSANGA | PO BOX 25525  
KAMPALA | UGANDA | **EAST AFRICA**

##### ALPINTER ASIA

ALPINTER ASIA LTD.  
RM 1902, HUA FU COMMERCIAL BLD.  
111 QUEENS ROAD WEST  
SHEUNG WAN | HONG KONG | **ASIA**

#### PRODUCTION SITE & PARTNER



[info@alpinter.com](mailto:info@alpinter.com) | [www.alpinter.com](http://www.alpinter.com)

**CONTACT US TODAY**

**SHELTER  
STARTS  
WITH US**

